

BIM Examples

Hyoungkwan Kim

Based on sources such as
 Taekwun Park, Moon Kyum Kim, Changyoon Kim, and Hyoungkwan Kim (2009). "Interactive 3D CAD for Effective Derrick Crane Operation in a Cable-Stayed Bridge Construction." Journal of Construction Engineering and Management, In press.
 Changyoon Kim, Hyoungkwan Kim, Taekwun Park, and Moon Kyum Kim (2009). "Interactive 3D CAD for Effective Derrick Crane Operation in a Cable-Stayed Bridge Construction." Journal of Computing in Civil Engineering, Submitted.
 Mohamed Al-Hussein, Muhammad Athar Niaz, Haitao Yu, Hyoungkwan Kim (2006). "Integrating 3D visualization and simulation for tower crane operations on construction sites." Automation in Construction, 15, 554-562.

Interactive 3D CAD for Effective Derrick Crane Operation in a Cable-Stayed Bridge Construction, (Park et al. 2009)

- Cable stayed bridges have recently gained increasing popularity.
- The unique nature of a civil engineering project tends to require construction methods customized for the specific project.
- With this unique conditions in the one-of-a-kind construction site, the constructability is at stake.
- In this study, an interactive 3D CAD system is proposed to predict potential problems in cable-stayed bridge constructions.

Two major methods for installing deck segments in cable-stayed bridge construction



Temporary bents method



Cantilever method

Case study description



Cheongpoong Grand Bridge

- Project location
 - Chungcheongbukdo , Jaechon, Korea
- Specification of cable-stayed bridge
 - Total Length = 442m
 - Main Span Length = 327m
 - Height of Pylon = 103m

Derrick crane for Cheongpoong Grand Bridge



Derrick crane specifications

Item	Value
Boom length	19.65 m
Mast length	12.67 m
Total Height	17.64 m
Vertical speed	Up 0~1m/min; Down 0~1.5m/min
Turning speed	0.15 radian/min

Deck segment installation procedure

1. As a precondition, the concrete deck of the side span is completed and two steel joints are connected to the concrete deck.
 - A rail is installed on the deck of the side span so as to easily move the derrick crane.
2. Move the derrick crane forward to the right position and anchor the crane to the lugs that are pre-installed.
3. Edge girders are moved and installed.
4. Man cages are placed for the bolting of the edge girders to the steel joints
5. Man cages are removed.
6. A safety net is installed using the two edge girders for the protection of the workers.
7. Floor beams are moved and installed.
8. Stringers are moved and installed.
9. Working platforms are moved and placed, and using the platforms, construction workers hang and partially stress cables

Deck segment installation procedure (Cont'd)

10. The working platforms are removed.
11. Six precast concrete panels are, one by one, moved and installed.
12. Cast-in-place concrete are used to join the precast concrete panels with each other and to the steel structural members (edge girders, floor beams, and stringers), resulting in the formation of a deck segment.
13. After three days of concrete curing, the cables are partially stressed again for the adjustment to the newly formed deck segment.
14. The rail is extended.
 - The rail is composed of two pieces: front part and back part.
 - To extend the rail, the back part is detached from the deck and installed as the new front part
 - the original front part becomes the back part. In this way, the rail can move forward continually.
15. The steps from 2 to 14 are repeated until the finish of the deck construction.

Derrick crane setting

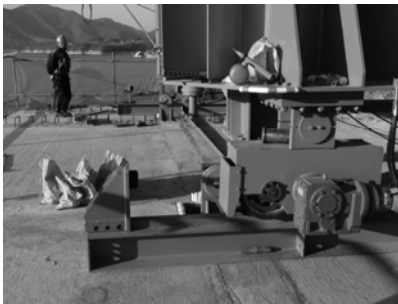

Edge girder installation

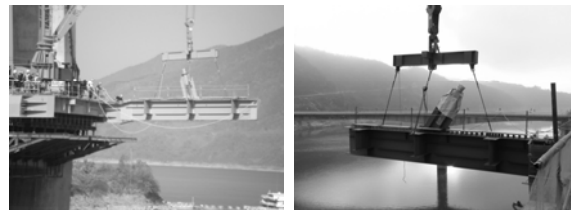

Man cage



Floor beam installation



Stringer installation



Working platform for cable hanging



Precast concrete panel installation



Cast-in-place concreting



Collision Check of Structural Members

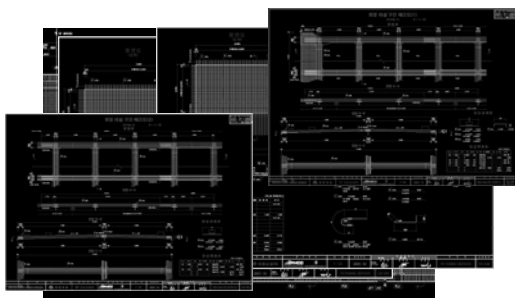

2D drawings

Collision Check of Structural Members (Cont'd)

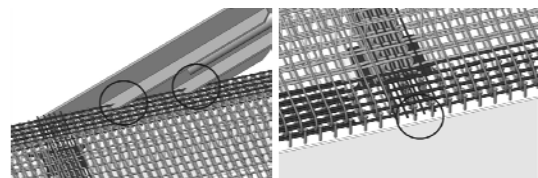

stay anchorage vs. reinforcing bar

stud vs. reinforcing bar

Material Unloading Space Analysis

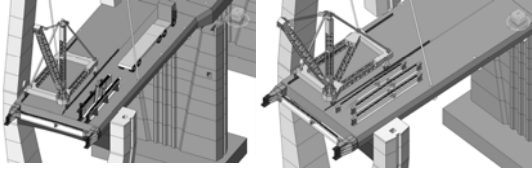

Material Unloading Space Analysis (Cont'd)

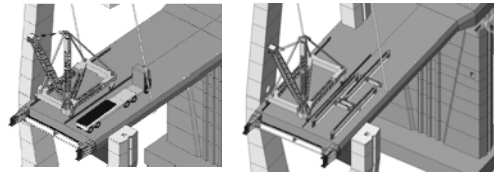

Separate installation of floor beams and stringers vs. T-shape beams

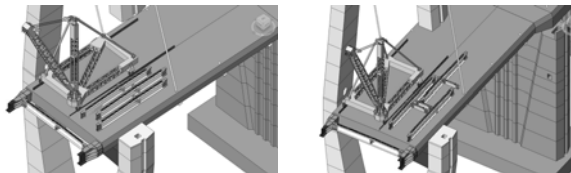

Crane operation analyses

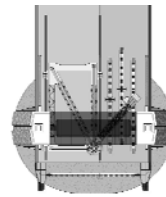

hoisting position



obstacle check in motion path

Crane operation analyses (Cont'd)

- Maximum capacity of the derrick crane for different structural components

Structural component	Weight	Maximum capacity of the derrick	
		Radius	Rotation angle (from the base line)
Edge girder	17 ton	13.53 m	245°
Floor beam	14.5 ton	16.1 m	245°
Stringer	8 ton	19 m	250°

Crane operation analyses (Cont'd)

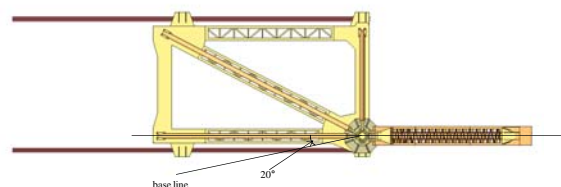

Baseline of the boom rotation

Crane operation envelopes with different loading conditions

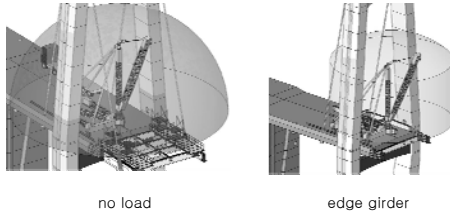

no load

edge girder

Crane operation envelopes with different loading conditions (Cont'd)

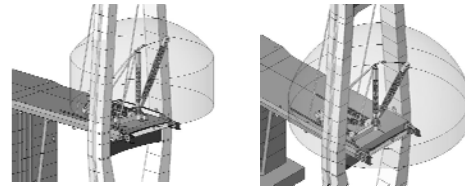

floor beam

stringer

Conclusions

- The purpose of this study was to identify the current capabilities and limitations of object-oriented 3D CAD in the application for bridge constructions.
- The object-oriented 3D CAD enabled the integration of different material-based 2D drawings, which led to the accurate and efficient identification of collision problems.
- The interactive nature of the 3D CAD allowed for the effective analyses of material unloading and crane operation space, based on various construction plans and scenarios.
- Construction engineers made the consensus that the 3D interactive system was an essential tool for promptly testing a range of construction conditions from spatial perspectives.

Conclusions (Cont'd)

- This study showed that the object-oriented 3D CAD was capable of improving construction productivity in bridge construction, by proactively analyzing spatial constraints.
- The 3D CAD usage prevented unnecessary reworks from happening, by predicting the most likely situations.
- On the other hand, from the T-shape member instance, it was found that the fancy 3D information should be accompanied by a sound engineering judgment.
- 3D models alone may mislead engineers to wrong decisions.
- This limitation indicates that one area for the future study should be how to incorporate field expertise, such as the tip for the floor beam alignment with edge girders, into the 3D model.

Applicability of 4D CAD in Civil Engineering Construction, (Kim et al. 2009)

- Unsatisfactory performance of construction projects often originates from inappropriate design, incomplete construction planning, and/or lack of communication between construction practitioners.
- To overcome the inefficiency of construction project management, constructability-oriented planning at the pre-construction or construction phase is essential.
- Four dimensional (4D) computer-aided design (CAD) is one of the promising methodologies that has been studied to aid in construction planning.
- However, there is a lack of 4D CAD application in the area of civil engineering

Some reasons for the lack of 4D CAD application in civil infrastructure constructions

- Civil engineering facilities are more heavily influenced by harsh site conditions than are architectural facilities.
- Construction activities of civil engineering facilities are not well organized in simple patterns, as not many activities are repeated in a civil engineering project.
- Civil infrastructure, in general, spans over a larger geographical area than do architectural facilities.
- This paper presents a case study in which 4D CAD was applied to civil engineering construction, in order to understand
 - an efficient way to develop a 4D CAD model,
 - the application procedure of the model to the actual civil construction site,
 - and the level of usefulness gained from the model.

Testbed (Cheongpoong Grand Bridge) description

- The bridge had a myriad of structural components, including two pylons, one main span, two side spans, and 92 cables.
- The main span is composed of 28 segments.
- Each segment has a total of 16 major structural components.
- Except for the precast concrete panels, all structural components (steel members) were manufactured offsite and delivered to the construction site.

Major structural components of the first deck segment

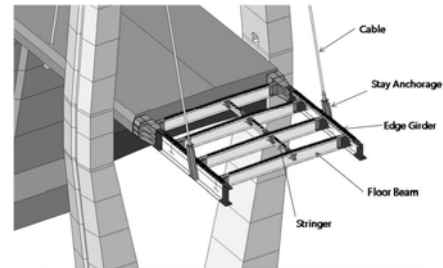

3D modeling of structural components for 4D visualization

- One of the most important prerequisites for 4D CAD modeling is to secure 3D models.
- Unfortunately, the Cheongpoong Grand Bridge was not originally designed in a 3D CAD environment – interoperability issue.
- If the objective of the 3D CAD model is simply to detect collision problems of more than one structural component in the finished facility, it is desirable to model all of the structural elements to their finest details.
- 3D models need to be detailed enough only to provide what is required in the next phase of 4D model analyses.
- From experienced engineers, a proper level of management can be determined.

3D modeling of structural components for 4D visualization (Cont'd)

- For the cable-stayed bridge, a total of 574 structural components were modeled in the 3D CAD environment.
- The most likely scenario was derived from analyzing the construction specifications and drawings.
- Experts' opinions were collected as to how the construction should be executed.
- This multitude of information was integrated in order to determine the 574 components that best match the construction management need with regard to activity level.
- In addition, the on-site engineers expressed the need to manage the construction on a more detailed level, that of the operation level.
- To this end, additional modeling was conducted to generate 3D components for equipment and temporary structures.

3D modeling of structural components for 4D visualization (Cont'd)

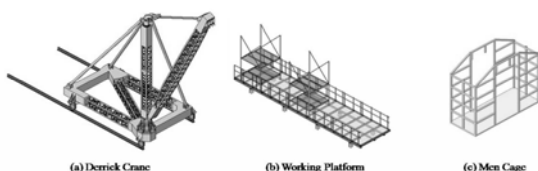

4D CAD modeling on the activity level

- To develop a 4D model, time schedule information is integrated with the existing 3D CAD components.
- Generally, 3D CAD systems that are currently available in the market do not have built-in functions that allow for this kind of information integration.
- In this study, commercial software – JetStream produced by NavisWorks – was used to combine the 3D CAD and time information.

4D CAD modeling on the activity level (Cont'd)

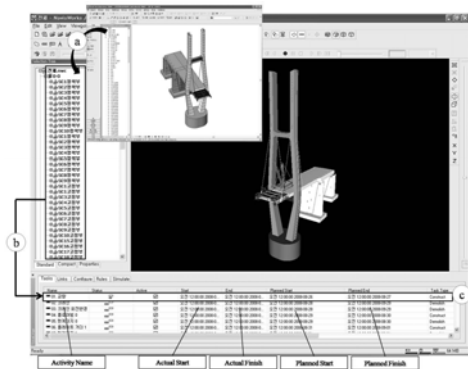

4D CAD modeling on the activity level (Cont'd)

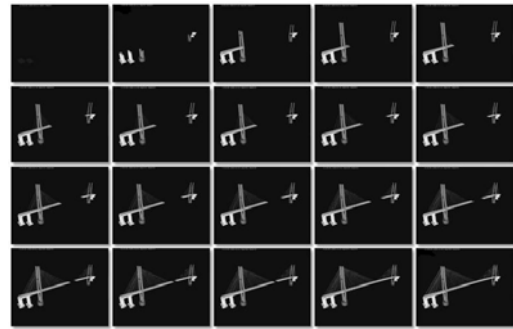

4D CAD modeling on the activity level (Cont'd)

- Once completed, 4D simulation could be displayed in many ways.
- In the 4D animation, start and finish times for a certain construction activity are clearly differentiated.
- Using the 4D model, actual construction progress can be compared with the original plan.
- The 4D CAD model created based on activity level has the advantages of better visualization and explanation of the construction project as compared to a 3D CAD model.
- However, activity level control of time and cost is often limited to relatively upper-level management.
- There are limitations in applying the 4D model for more detailed constructability and productivity analyses.

Discrete 4D CAD modeling on the operation level

- A more detailed modeling – discrete 4D CAD modeling on the operation level – was conducted.
- Here, the term 'operation level' was used to imply that this model places more emphasis on the construction methods.
- The rich information combined in the operation level model can guide the construction engineers much more accurately as to how the actual operation should be executed.
- Nevertheless, the process of developing the operation level 4D model is not much different from what is used for the activity level 4D model.
- The operation 4D modeling has its own limitation; it cannot show the continuous movement of equipment operation. it cannot show the continuous movement of equipment operation.

Comparison between activity and operation level 4D CAD

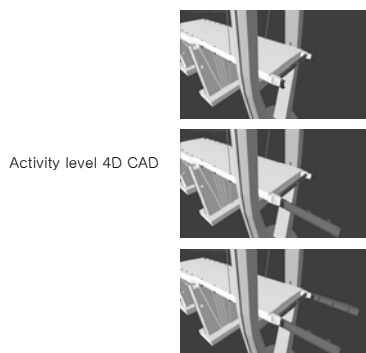

Comparison between activity and operation level 4D CAD (Cont'd)

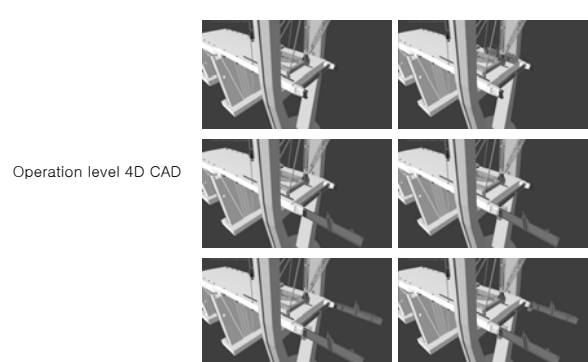

Continuous 4D CAD modeling on the operation level

- 'Continuous' 4D CAD modeling signifies that the resultant model depicts the construction operation for a continuous period of time, with no time lapses.
- In this methodology, entire movement processes of construction equipment, such as derrick cranes and trailers, are displayed like motion pictures.
- In this study, the continuous 4D CAD model was developed in the Autodesk Inventor platform.

Continuous 4D CAD modeling on the operation level (Cont'd)

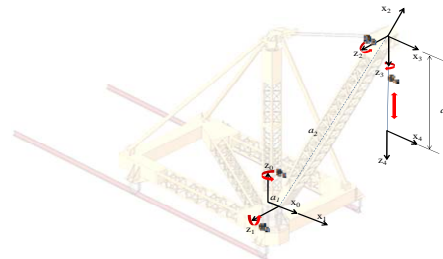

Reference frames for the derrick crane operation

Continuous 4D CAD modeling on the operation level (Cont'd)

$$A_{12} = \begin{bmatrix} c_1 & 0 & -s_1 & 0 & 0 & 0 \\ s_1 & 0 & c_1 & 0 & 0 & 0 \\ 0 & 1 & 0 & 0 & 0 & 0 \\ 0 & 0 & 0 & 1 & 0 & 0 \\ 0 & 0 & 0 & 0 & 1 & 0 \\ 0 & 0 & 0 & 0 & 0 & 1 \end{bmatrix}$$

$${}^0T_4 = A_1 A_2 A_3 A_4$$

$$= \begin{bmatrix} c_1 & 0 & s_1 & 0 & 0 & 0 \\ s_1 & 0 & -c_1 & 0 & 0 & 0 \\ 0 & 1 & 0 & 0 & 0 & 0 \\ 0 & 0 & 0 & 1 & 0 & 0 \\ 0 & 0 & 0 & 0 & 1 & 0 \\ 0 & 0 & 0 & 0 & 0 & 1 \end{bmatrix} \times \begin{bmatrix} c_2 & -s_2 & 0 & 0 & 0 & 0 \\ s_2 & c_2 & 0 & 0 & 0 & 0 \\ 0 & 0 & 1 & 0 & 0 & 0 \\ 0 & 0 & 0 & 1 & 0 & 0 \\ 0 & 0 & 0 & 0 & 1 & 0 \\ 0 & 0 & 0 & 0 & 0 & 1 \end{bmatrix} \times \begin{bmatrix} c_3 & -s_3 & 0 & 0 & 0 & 0 \\ s_3 & c_3 & 0 & 0 & 0 & 0 \\ 0 & 0 & 1 & 0 & 0 & 0 \\ 0 & 0 & 0 & 1 & 0 & 0 \\ 0 & 0 & 0 & 0 & 1 & 0 \\ 0 & 0 & 0 & 0 & 0 & 1 \end{bmatrix}$$

$$= \begin{bmatrix} c_1 c_2 c_3 c_4 - s_1 s_2 s_3 c_4 + s_1 s_2 c_3 & -s_1 c_2 c_3 c_4 + c_1 s_2 s_3 c_4 + s_1 c_2 c_3 & c_1 c_2 s_3 c_4 + c_1 s_2 s_3 c_4 + c_1 s_2 c_3 & c_1 c_2 c_3 s_4 - c_1 s_2 s_3 s_4 - c_1 s_2 c_3 & -s_1 c_2 c_3 s_4 + c_1 s_2 s_3 s_4 - c_1 s_2 c_3 & s_1 c_2 c_3 c_4 + c_1 s_2 s_3 c_4 + c_1 s_2 c_3 \\ s_1 c_2 c_3 c_4 - c_1 s_2 s_3 c_4 - c_1 s_2 c_3 & -s_1 c_2 c_3 s_4 + c_1 s_2 s_3 s_4 - c_1 s_2 c_3 & c_1 c_2 s_3 s_4 + c_1 s_2 s_3 s_4 + c_1 s_2 c_3 & c_1 c_2 c_3 c_4 + c_1 s_2 s_3 c_4 + c_1 s_2 c_3 & -s_1 c_2 c_3 c_4 + c_1 s_2 s_3 c_4 - c_1 s_2 c_3 & s_1 c_2 c_3 s_4 + c_1 s_2 s_3 s_4 + c_1 s_2 c_3 \\ s_1 c_2 c_3 s_4 + c_1 s_2 s_3 s_4 & -s_1 c_2 c_3 c_4 + c_1 s_2 s_3 c_4 - c_1 s_2 c_3 & -s_1 c_2 c_3 s_4 + c_1 s_2 s_3 s_4 - c_1 s_2 c_3 & c_1 c_2 c_3 s_4 - c_1 s_2 s_3 s_4 - c_1 s_2 c_3 & -s_1 c_2 c_3 c_4 + c_1 s_2 s_3 c_4 - c_1 s_2 c_3 & s_1 c_2 c_3 s_4 + c_1 s_2 s_3 s_4 + c_1 s_2 c_3 \\ s_1 c_2 c_3 c_4 - c_1 s_2 s_3 c_4 - c_1 s_2 c_3 & -s_1 c_2 c_3 s_4 + c_1 s_2 s_3 s_4 - c_1 s_2 c_3 & -s_1 c_2 c_3 c_4 + c_1 s_2 s_3 c_4 - c_1 s_2 c_3 & -s_1 c_2 c_3 s_4 + c_1 s_2 s_3 s_4 - c_1 s_2 c_3 & -s_1 c_2 c_3 c_4 + c_1 s_2 s_3 c_4 - c_1 s_2 c_3 & s_1 c_2 c_3 s_4 + c_1 s_2 s_3 s_4 + c_1 s_2 c_3 \end{bmatrix}$$

Denavit-Hartenberg representation

Continuous 4D CAD modeling on the operation level (Cont'd)

i	θ (°)	d_i (m)	a_i (m)	α (°)
1	θ_1	0	a_1	90°
2	θ_2	0	a_2	0°
3	θ_3	0	0	90°
4	θ_4	d_4	0	0°

Denavit-Hartenberg parameters for the crane operation

Continuous 4D CAD modeling on the operation level (Cont'd)

- In the Inventor platform, the local coordinate systems are defined based on the concept of constraint conditions.
- Constraint conditions are established to define the object to be moved and the reference frame.
- The following figures shows the overall process of developing a continuous operation level 4D CAD model with three steps: definition of constraint conditions, range setup for movement angles and distance, determination of movement durations with start and end times.

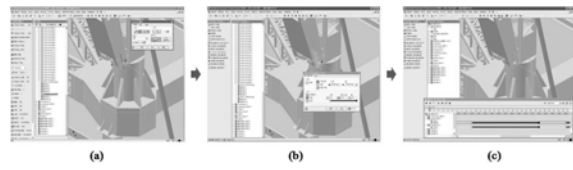

Continuous 4D CAD modeling on the operation level (Cont'd)

In order to represent the boom and mast rotation, constraint conditions were established as follows.

- First, when the mast was approximated to be a square column, the center points were defined for the top square plane and the bottom square plane.
- The line that goes through the two center points was defined as the longitudinal axis of the mast.
- Likewise, the particular base corner on which the mast rested was approximated to be a cylindrical column.
- In the same manner as the mast, the longitudinal axis was defined with the two center points on the top and bottom planes (circles).
- Next, the longitudinal axis of the mast was positioned such that the distance and angle between the mast axis and the longitudinal axis for the base corner both became zero.

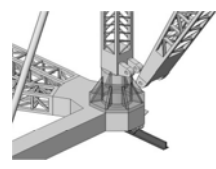

Mast bottom hinges and boom bottom hinges

Continuous 4D CAD modeling on the operation level (Cont'd)

- To be exact, the bottom plane of the mast met with the top plane of the base corner, in order to put the mast on top of the base corner.
- A plane that contained the longitudinal axis for the mast was defined.
- Likewise, a plane that contained the longitudinal axis for the base corner was defined.
- Then, the angle between the two planes determined the rotation angle of the boom and mast.
- These conditions, such as longitudinal line definitions, plane definitions, and location and angle definitions, are what are referred to as constraint conditions.

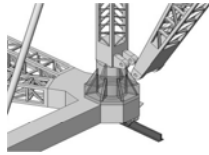

Mast bottom hinges and boom bottom hinges

Continuous 4D CAD modeling on the operation level (Cont'd)

- To represent the vertical movement of the boom, a series of constraint conditions were also established.
- Two axes were defined: one going through the two hinge holes at the mast bottom and the other going through the two hinge holes at the boom bottom.
 - Then, the boom bottom axis was moved such that the entire boom axis overlapped the mast bottom axis.
 - To be exact, the plane defined by the outer surface of the mast hinge became the same as the plane defined by the inner surface of the boom hinge.
 - In this way, the mast and the boom are connected properly at the hinges.

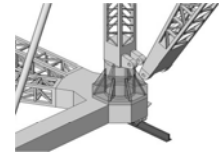

Mast bottom hinges and boom bottom hinges

Continuous 4D CAD modeling on the operation level (Cont'd)

- Next, a plane was defined, one that contained the mast bottom axis and was perpendicular to the longitudinal axis for the mast.
- A second plane was also formed, one that contained the boom bottom axis and was parallel with the longitudinal axis for the boom.
- The longitudinal axis for the boom was defined in the same manner as that of the mast.
- Finally, changing the angle between the two planes with time durations visually lifted the boom up or down.
- Again, the definitions for axes, planes, and angles, along with the location information, form the series of constraint conditions.

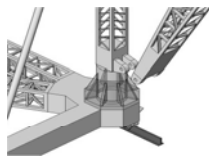

Mast bottom hinges and boom bottom hinges

Continuous 4D CAD modeling on the operation level (Cont'd)

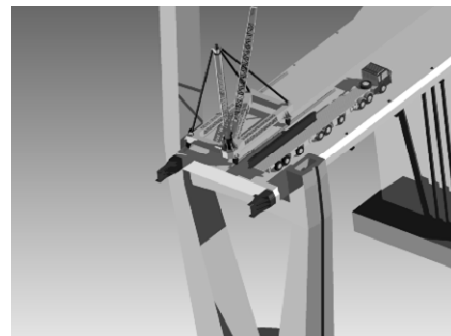

Continuous 4D CAD modeling on the operation level (Cont'd)

- Sometimes, a continuous 4D model is mistaken to be a fixed graphic animation, especially when the simulation is passively played and observed.
- In contrast, the continuous 4D model, like the discrete 4D CAD model, can be used in a dynamic way.
- Virtually any perspective view can be chosen at any resolution to concentrate on a particular structural member being installed at a certain time.
- The continuous 4D model is also advantageous in its reflection of the realistic operation time.

Comparisons of the three 4D CAD models

Visualization element	Visualization capacity		
	4D CAD activity level model	Discrete 4D CAD operation level model	Continuous 4D CAD operation level model
Materials used as a part of the facility	High	High	High
Unused materials on site	Low	High	High
Equipment	Low	Middle	High
Temporary structures	Low	High	High
Work space analyses	Low	Middle	High

Discussions

- The three 4D models were quite helpful for the smooth execution of the project, especially in the area of communication management.
- The engineers for the contractor could easily communicate with the engineers for the subcontractors, with the use of the 4D models.
- All of the engineers agreed that the communication capacity strengthened by the continuous 4D model was significant.
- However, there were some downsides to the continuous model.
- The time and effort required to develop the model was relatively higher than that for the other models.
- Furthermore, the revision of the continuous model with the refined feedback from the field required even more time and effort.
- This confirmed the need for future research to facilitate the development of the continuous model.
- Unlike the continuous model, the discrete 4D operation level model provided a good balance between the detail level of the model and the effort required for model development.
- Even in the revision process, the discrete operation level 4D model did not require much effort, compared with the activity level 4D model.

Conclusions

- One of the unique contributions of this study was that three different 4D CAD models were applied to the real-life bridge project, to discover a way of choosing appropriate 4D models for various scenarios of civil engineering construction.
- The 4D CAD activity level model was the best for the analysis of the entire construction project.
- Meanwhile, a higher level of work space analysis was possible with the discrete and continuous 4D operation level models, due to their abilities to represent such detailed construction objects as the derrick crane and temporary structures.
- Nonetheless, the continuous 4D operation level model showed the best communication capacity among project participants.
- The discrete 4D operation level model showed a high benefit to cost ratio; compared to the effort required to generate the 4D model, its benefit was relatively high.
- The 4D models were proven to be good tools for planning, constructability analysis, and communication in civil infrastructure projects.

Integrating 3D visualization and simulation for tower crane operations on construction sites

- Computer simulation proved to be an effective tool for aiding practitioners in modeling complex construction operations.
- However, the use of simulation as a construction planning tool has fallen far below its maximum potential.
- The aforementioned problems justify the need for support tools that allow construction managers to construct simulation models and analyze results for themselves.
- Special purpose simulation (SPS) and 3D visualization of simulated operations are two potential means by which this goal can be achieved.

System Components

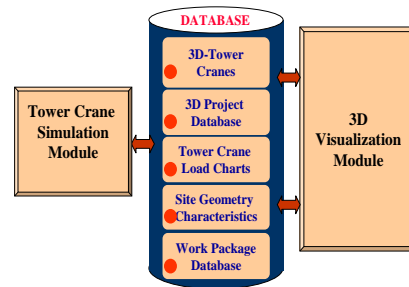

3D Transformations

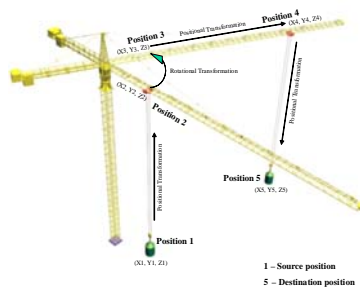

Case Study

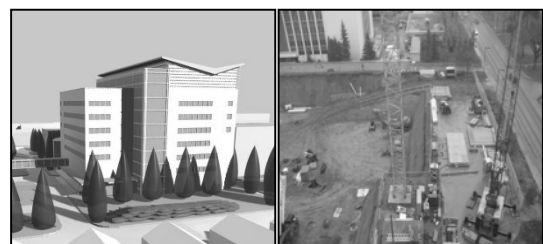

Natural Resources Engineering Facility (NREF), Edmonton

Simulation in Simphony

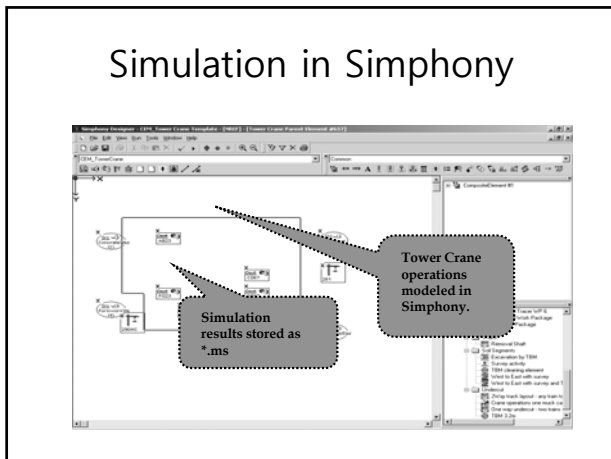

SimAnim – 3D Studio Max

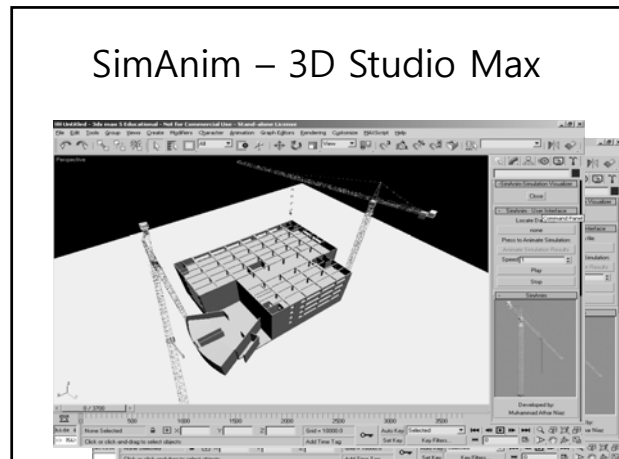

Conclusions

- This paper described and discussed the challenges met and the approach adopted in an effort to develop an SPS and 3D visualization integration system to improve the credibility and communication of simulated construction operations.
- This paper demonstrated the effectiveness of utilizing 3D visualization and simulation modeling in better understanding construction operations.
- This is particularly helpful for simulation verification and validation.